

PRO SERIES PUMP

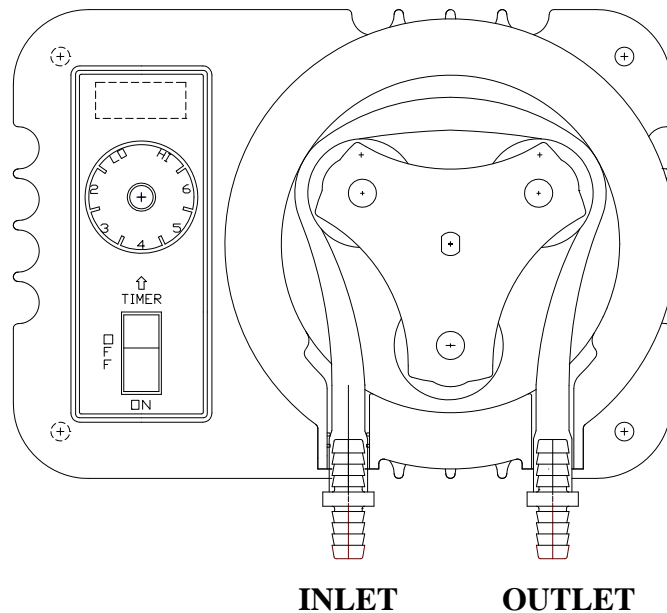

IMPORTANT SAFETY INSTRUCTIONS

When installing and using this product, basic safety precautions should always be followed, including:

- Wear protective clothing, gloves and safety glasses at all times when working on or near the metering pump.
- Install the metering pump and chemical containers in a ventilated secured location to protect children, pets, and property from chemical hazards. Containment and/or wash down capability must be in accordance with local regulations and chemical suppliers' instructions.
- Read and follow all instructions supplied with the chemical being fed. User is responsible for determining the compatibility of the chemical with the metering pump. Consult supplier of chemical if use and handling instructions are not available.
- De-pressurize the system prior to connecting or disconnecting the metering pump.

CONTENTS

Section title	Page
-- Important Safety Instructions	cover
1. Safety Instructions	2
2. Specifications	3
3. Installation	4
4. Operation	5
5. Maintenance	5
6. Trouble Shooting	6
7. Chemical Feed Pump Size Requirements	7
8. Parts List	8
9. Warranty and Service	10

1. SAFETY INSTRUCTIONS

WARNING! --- To reduce risk of injury, do not permit children to use this product unless they are closely supervised at all times.

WARNING! --- Risk of electrical shock. Only connect cord and plug units to a grounding receptacle protected by a ground-fault interrupter (GFIC).

WARNING! --- Risk of electric shock. On cord and plug connected units, replace a damaged cord immediately. Do not use extension cord to connect unit to electrical supply; provide a properly located outlet. Do not bury or modify the metering pump cord. Locate cord to minimize abuse from lawn mowers, hedge trimmers, and other equipment.

Do not install within an outer enclosure or beneath the skirt of a hot tub or sap unless so marked. All instructions must be in accordance with appropriate electrical codes.

WARNING! --- Disconnect power sources or lockout circuit prior to performing maintenance on metering pump. Pumps are usually timer controlled and can start at any time.

CAUTION! --- This pump is for use with permanently installed pools and may also be used with hot tubs and spas. Do not use with storable pools. A permanently installed pool is constructed in or on the ground or in a building such that it cannot be readily disassembled for storage. A storage pool is constructed so that it is capable of being readily disassembled for storage and reassembled to its original integrity.

CAUTION! --- Service tubing regularly, especially when refilling chemical container. See operation instruction.

2. SPECIFICATIONS:

**Power: 120 volt AC (corded) or 240 volt AC (conduit)
50/60 HZ,
2.5 amp (max.)**

**Pressure/suction:
30 psi max. dispense line pressure
18 foot max. inlet suction lift**

Capacity: ESTIMATED MAXIMUM GALLONS PER DAY

SETTING	ON	OFF	RC252	RC25/53	RC103	RC503
LO	4 SEC	9 MIN	0.01	0.10	0.30	0.80
2	1.5 MIN	7.5 MIN	0.10	1.20	3.20	7.20
3	3 MIN	6 MIN	0.30	3.60	9.60	22.00
4	4.5 MIN	4.5 MIN	0.50	6.00	16.00	36.00
5	6 MIN	3 MIN	0.70	8.40	22.00	50.00
6	7.5 MIN	1.5 MIN	0.90	11.00	29.00	65.00
HI	9 MIN	4 SEC	1.00	12.00	32.00	72.00

3. INSTALLATION:

Tools required – 23/32” drill bit, 1/2” pipe tap and Phillips screwdriver.

- 1) Install the ROLA-CHEM pump in an area protected from natural elements (sun, rain, freezing, etc.). The inlet side of the pump must be above the incoming liquid and the chemical container. Flooded suction is not required or recommended. Ensure that the tube can be routed without allowing it to kink. Do not install directly above the chemical container or other equipment that can be damaged by chemicals. Wall mounting key slots are provided on the rear of the pump enclosure (6.25 “ apart for #10 screws). Comply with local health codes, cross connections must not allow undesired chemical treatment.
- 2) The ROLA-CHEM pump is designed to develop a suction lift of 18 feet and to pump into a pressure line of up to 30 psi. Do not exceed these limits. The use of undiluted swimming pool grade, 15% maximum sodium hypochloride is recommended. If Tri-cloro or Dicloro is used, do not exceed solution strengths of .4 lbs/gal for Tri-cloro or 1 lb/gal for Di-cloro. Norprene pump tubing (black) is included for 32% maximum hydrochloric acid feed or Tri-cloro feed.

CAUTION:- Do not mix chemicals.

- 3) Connect the injection fitting into the line to be treated. On a swimming pool make sure this is after the heater. The brass injection fitting will fit a 1/2 NPT pipe thread connector or a 1/2 NPT hole tapped into heavy gage pipe. Push the vinyl tube through the fitting until it hits the bottom of the pipe, then pull it back about 1/4 “. This creates an outlet for chlorine away from the injector fitting and helps the injector fitting from becoming clogged. For installations where a 1/4 NPT injection port connection is already provided a 1/4 NPT adapter with a tubing clamp is included in the literature kit. Remove the brass injection fitting when using this adapter. Use pipe tape to seal the pipe threads.
- 4) Place the suction tubing in the chemical container with the weight lying on its side. This will keep the end of the suction tubing off the bottom to allow for sediment.
- 5) Electrical hook-up must comply with Code, including safety devises. Voltage must be as listed on the data plate. **CAUTION:** Pump must be wired to prevent overdosing. Connect to turn off with circulating system and /or connect to a flow switch on the return piping. Pump must be turned off when backwashing filters.

4. OPERATION:

- 1) Before placing the ROLA-CHEM pump in operation, lubricate the pump hose with a small amount of silicone lubricant supplied in the literature kit. To access the pump hose remove the knob from the front of the pump housing. Rotate the housing cover counterclockwise and lift off the cover or on the RC252 Models remove wing nuts and lift off the body half.

CAUTION: Remove power from pump when lubricating tubing. Do not remove tubing from pump housing while system is under pressure.

NOTE: Maintain lubrication on the pump hose at all times.

- 2) The three-way switch has Timer, Off and On positions. For non-stop chemical feeding use the On position. For interrupting action, use the Timer position and adjust the timer knob for the desired output. The timer reduces the output by interrupting the chemical feeding for the selected portion of its nine minute timing cycle (setting of 4 provides approximately 4.5 minutes On and 4.5 minutes Off). The pump will feed at its maximum rate relative to operating conditions whenever it is feeding. Where an extremely accurate feeding setting is required, use a calibrated cylinder and a stopwatch to calculate the amount fed under actual operating conditions. Be sure to use full timer cycles when making the calculations. See rate chart for nominal feed rate settings.

5. MAINTENANCE:

Crystal buildup is seldom a problem with ROLA-CHEM pumps. However, in very hard water areas it may be necessary to flush the pump hose and tubing. Use plain water or a weak solution of muriatic acid (1/2 pin muriatic acid to one gallon of water).

CAUTION: Always add acid to water; wear protective clothing, gloves, and safety glasses.

Preventive maintenance is the best defense against possible leaks. Remove the tubing assembly when the pump is not in use.

CAUTION: System pressure must be removed prior to releasing the tubing to prevent backflow. Plug the injection fitting. A check valve may be used at the point of injection to prevent backflow, then the tubing assembly can be disconnected at its connection to the check valve and it will not be necessary to plug the injection fitting hole.

Place the tubing in a clean poly bag when not in use. The pump shipping bag may be saved for this purpose. Inspect tubing as stated in safety instructions and lubricate pump hose often to maintain the coating of silicone grease. Replace the pump hose when found to be deteriorating or at the start of a new season. A pump hose under light duty may last more than one season- but the cost of a pump hose is far less than a damaged pump or an unscheduled maintenance call.

6. TROUBLE SHOOTING PUMP PROBLEMS:

Issue	Cause	Action
Pump does not operate, noise, no motion	Power	Check power source, switches, no circuit box, ground fault tripping, etc.
Pump will not shut off with in 'Timer' position	Switch or timer	Replace switch or timer switch
Pump motor turning but no movement in the roller assembly.	Motor gearbox	Replace motor
Short hose life	Worn or loose components	Replace worn roller assembly/secure pump housing and cover
	Lubrication	Lubricate pump hose more frequently
	System pressure	Check system pressure, 30 PSI max.
Pump rotating but not pumping fluid	Pump hose	Replace pump hose
	Roller assembly	Replace roller assembly
	Motor bearings	Replace motor
Pump motor starts and stops with switch in "On" position.	High temperatures	Check fan, replace if damaged. Improve ventilation to pump
	Switch	Replace switch

7. CHEMICAL FEED PUMP SIZE REQUIREMENTS:

WARNING ! FAILURE TO USE PROPER SIZE FEEDER MAY RESULT IN INJURY.

NOTE: ORP/pH controllers will not function properly with over or undersized feeder.

<u>SPA CAP. IN GALS</u>	<u>POOL CAP. IN GALS</u>	<u>CHLORINE PUMP</u>	<u>ACID PUMP</u>
500-2,500		RC 252 (1 GPD)	SAME**
2,500-25,000		RC 25/53 (12GPD)	SAME**
	2,500-5,000	RC 252 (1 GPD)	SAME**
	5,000-65,000	RC 25/53 (12GPD)	SAME**
	65,000-180,000*	RC 103 (32 GPD)	RC 25/53 (12 GPD)
	180,000-400,000*	RC 503 (72 GPD)	RC 25/53 (12 GPD)

Sizing chart is based on Rola-Chem or equivalent pumps using 10.5+ % Sodium Hypochlorite and Muriatic strength Hydrochloric Acid.

When feeding acid diluted 9:1, the acid pump may be the same size as the chlorine (NaHOCl) pump.

**Where 'SAME' is specified, dilute acid 4:1 to 9:1.

Warning! Only add acid to water (i.e. fill tank with 4 gallons of water then add gallon of acid).

Actual pump size may vary when diluting chemicals, size pumps based on dilution ratio and available pump sizes. Pump size must be in compliance with local health codes. When in doubt about pump size or if different brand feed pumps are used, consult your supplier or Rola-Chem.

*RC103 pumps have been successfully used on pools up to 240,000 gallons (RC 503 pumps to 500,000 gallons).

Caution! Erosion feeders must also be sized to body of water, refer to appropriate sizing data from feeder manufacturer.

8. PARTS LIST

ITEM	PART NUMBER	DESCRIPTION	MODEL			
			RC252	RC25/53	RC103	RC503
1	527253	ENCLOSURE COVER NS	X	X	X	X
2	527251	ENCLOSURE BODY NS	X	X	X	X
3	525253	SCREW 10-24 x 4-1/2 PPH STL ZP	X	X	X	X
4	521752	HOUSING, BODY		X	X	X
5	521751	HOUSING, COVER		X	X	X
6	523408	KNOB, LOCK ASSY		X	X	X
7	523400	ROLLER, TRI NS-ASSY (3 ROLLER)		X	X	X
8	525233	SCREW 10-24 x 3/4 PTH SST		X	X	X
9	521225	HOUSING, PUMP	X			
10	525004	BRASS STUD 10-32	X			
11	525140	WING NUT 10-32	X			
12	523332	ROLLER, 2 INCH H-BLOCK	X			
13	521058	GEAR MOTOR, 1R, 120V	120 V			
	521094	GEAR MOTOR, 1R, 240V	240 V			
	521805	GEAR MOTOR, 4R, 120V		120V		
	521806	GEAR MOTOR, 4R, 240V		240V		
	521316	GEAR MOTOR, 16R, 120V			120V	
	521317	GEAR MOTOR, 16R, 240V			240V	
	524754	GEAR MOTOR, 30R, 120V				120V
	524755	GEAR MOTOR, 30R, 240V				240V
14	-----	FAN, 3 INCH		CONSULT FACTORY		
15	524717	TIMER/POT ASSY 120 V		ALL 120 V PUMPS		
	524718	TIMER/POT ASSY 240 V		ALL 240 V PUMPS		
16	521154	KNOB, TIMER	X	X	X	X
17	524711	SWITCH ASSY, 3 WAY	X	X	X	X
18	524155	POWER CORD, 18-3SJT, 120V		120 VOLT PUMP-CORDED		
	524156	POWER CORD, 18-3SJT, 240V		240 VOLT PUMP-CORDED		
19	524070	STRAIN RELIEF		CORDED PUMPS		
20	523252	HOSE ASSY-COMPLETE 8 INCH	(NOTE 2) X			
	523118	HOSE ASSY-COMPLETE 13.5 INCH	(NOTE 2)	X	X	X
21	525114	CLAMP, HOSE #8	X	X	X	X
		FITTING, HOSE CONNECTOR, 3/8 BARB				
22	520111	BARB	X	X	X	X
23	520110	CLAMP, HOSE #6	X	X	X	X
24	520120	TUBING, VINYL .31 X .44 X 66 INCH	X	X	X	X
25	527158	BRASS INJECTION FITTING	X	X	X	X
26	523110	WEIGHT, HOSE 7/16	X	X	X	X
27	520112	RETAINER-HOSE WEIGHT	X	X	X	X
28	523102	LUBRICANT, E-Z GLIDE, 3GRAM	X	X	X	X
29	520113	ADAPTER, PP1/4MNPTx 3/8 BARB	X	X	X	X
30	523251	NORPRENE HOSE ASSY-8 INCH	(NOTE 1) X			
	523114	NORPRENE HOSE ASSY-13.5 INCH	(NOTE 1)	X	X	X
	523250	TYGON HOSE ASSY-8 INCH	(NOTE 1) X			
	523115	TYGON HOSE ASSY-13.5 INCH	(NOTE 1)	X	X	X
31	524115	J-BOX		CONDUIT MODELS		
32	524135	LOCK NUT, STEEL 1/2		CONDUIT MODELS		
33	524110	NIPPLE, 1/2 X 1		CONDUIT MODELS		
34	525214	GROUND SCREW #8, GREEN	X	X	X	X
35	525255	LOCK WASHER (GROUND SCREW)	X	X	X	X
36	521160	CHECK VALVE, PVC, 3/8 X 3/8 BARB		ACCESSORY		
		CHECK VALVE, PVC, 3/8 BARB X 1/4 NPT		ACCESSORY		
37	521170	NPT		ACCESSORY		
38	525113	SEAL, INJECTION FITTING (SPARE)		ACCESSORY		

NOTE 1 :ITEM #30 INCLUDES TYGON HOSE (OR NORPRENE HOSE), HOSE CAMP (ITEM #21) AND FITTINGS (ITEM #22)

NOTE 2 :ITEM #20 INCLUDES TYGON HOSE ASSY (ITEM #30) AND ITEMS 23 THRU 27

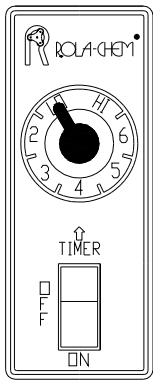

TIMER POSITIONS

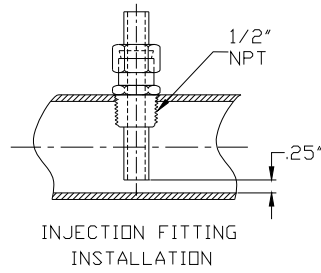

INJECTION FITTING INSTALLATION

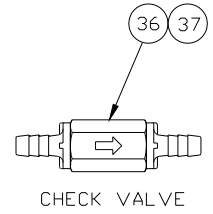

CHECK VALVE

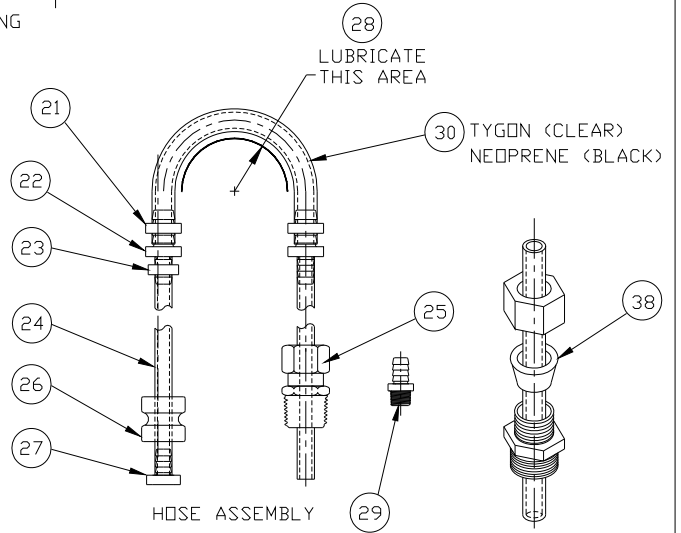

HOSE ASSEMBLY

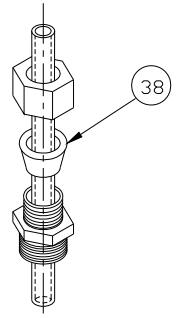

INJECTION FITTING

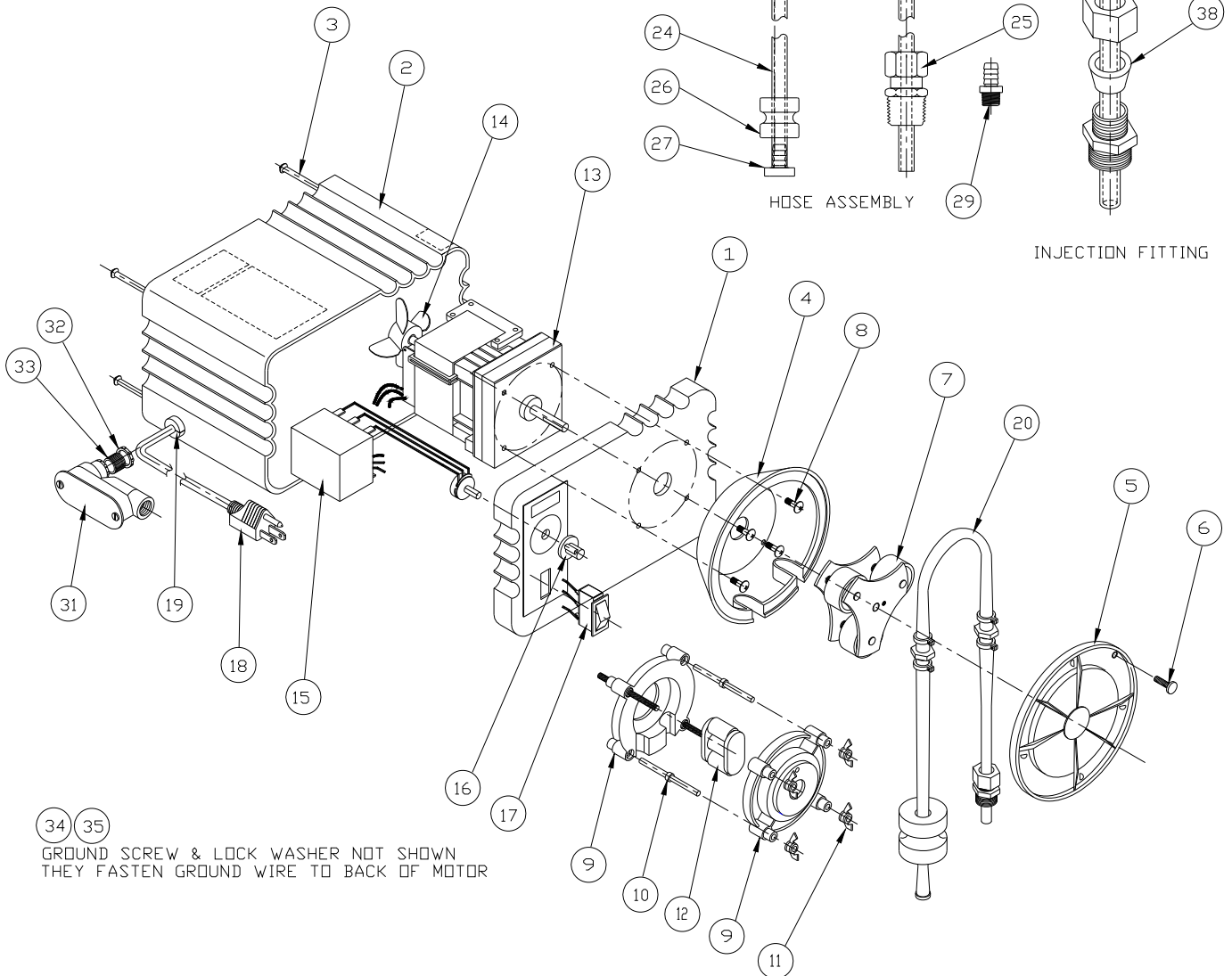

34 35
GROUND SCREW & LOCK WASHER NOT SHOWN
THEY FASTEN GROUND WIRE TO BACK OF MOTOR

WARRANTY AND SERVICE:

Limited Warranty:

Rola-Chem Corporation warrants the original purchaser that this unit is free from manufacturing defects in material and workmanship from the date of the original purchase for one (1) year. If this unit fails within the one (1) year period, it will be repaired or replaced (Rola-Chem's option) at no charge, when returned to Rola-Chem Corporation with proof of purchase receipt. This warranty does not apply to any product damage caused by improper use, accident, misuse, improper line voltage, fire, flood, lightening, earthquake or other acts of nature, or, if product was altered or opened by anyone other than qualified Rola-Chem personnel.

All expendable items- hoses, etc., are not covered under this warranty.

Rola-Chem Corporation, under no circumstances, shall be liable for any consequential damages directly or indirectly caused by this unit. Please observe all rules and regulations required by state and local regulations, building codes, health codes, OSHA, etc.

Service Procedure:

For operation assistance in the United State, please call:
(800) 549-4473 or FAX (651)-653-0989
Monday thru Friday 8:00 am-5:00 pm, Central Time.

Rola-Chem Corporation has specialized knowledge and equipment to properly test your unit and help you with special problems. After talking to our service personnel, the product in need of service should be shipped with RGA#, freight prepaid, via UPS if at all possible to:

Rola-Chem Corporation
5858 Centerville Road
St. Paul, MN 55127-6804

- NOTES -

- NOTES -